

aisa **HAWK** hyperspectral sensor

AisaHAWK is the smallest airborne SWIR hyperspectral sensor on the market. It is designed to provide high quality data in SWIR range (970 to 2500 nm). AisaHAWK employs the highest sensitivity cooled MCT SWIR detector technology and temperature stabilized optics in order to guarantee the highest stability and signal-to-noise ratio during long flight missions.



Hawk II sensor
 L: 220 mm
 W: 275 mm
 H: 470 mm
 Mass: 18 kg

AisaHAWK is the first small and low maintenance SWIR (970-2500 nm) hyperspectral sensor that provides high speed data acquisition at high sensitivity. The major advantages of the AisaHAWK are its distinctive size, high quality of data and low investment cost. AisaHAWK is the most compact SWIR hyperspectral sensor on the market, and can be quickly and easily installed in any aircraft. The AisaHAWK sensor is designed and tested to meet MIL vibration and shock specifications.

HIGH PERFORMANCE

The AisaHAWK sensor employs Mercury Cadmium Telluride (MCT) SWIR detector technology which provides the highest sensitivity and signal-to-noise ratio over the full SWIR range

of 970 to 2500 nm. The transmissive imaging spectrograph is nearly independent of the polarization in the incoming light, and provides high diffraction efficiency and uniform spectral resolution of 10 nm over the full SWIR range.

All the optics (fore optics and imaging spectrograph) and the detector assembly are temperature-stabilized. It ensures the highest radiometric stability and image quality during flight missions.

AisaHAWK can be integrated with the AisaEAGLE sensor to make a dual sensor system, which provides seamless hyperspectral data in the full range from 400 to 2500nm. For more information, please see the AisaDUAL data sheet.

AisaHAWK Airborne Hyperspectral Imaging System

SPECIM provides AisaHAWK as a full, ready-to-use turnkey system. The complete AisaHAWK system consists of

- The AisaHAWK sensor
- Image acquisition computer with a user-friendly interface and image acquisition software (RSCube)
- High performance GPS/INS sensor
- Power supply
- CaliGeo pre-processing software

For more information about the complete system, please see the AISA Systems brochure and CaliGeo brochure.

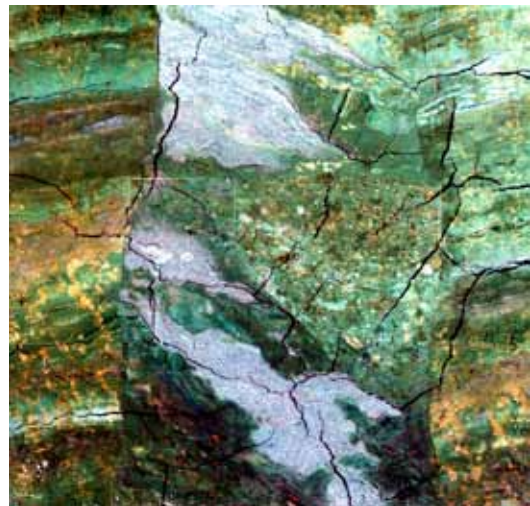

All AISA sensors can also be used for ground-based hyperspectral imaging. Ragona, D et al. have studied the classification of sediments of very similar composition and grain size using the SWIR sensor. (Courtesy of Ragona, D., Minster, B., Rockwell, T., Jasso, H.)

AisaHAWK

OPTICAL CHARACTERISTICS		TYPICAL SPECIFICATIONS		
Spectrograph	High efficiency transmissive imaging spectrograph. Throughput practically independent of polarization. Smile and keystone < 5 microns. Spectrograph is temperature stabilized.			
Numerical aperture	F/2.0			
Spectral range	970 - 2500 nm			
Spectral sampling/pixel	6.3 nm			
Spectral resolution	12 nm			
Slit width	30 microns			
Calibration	Sensor provided with wavelength and radiometric calibration file.			
FORE OPTICS				
FOV	17.8 degrees	24.0 degrees	35.5 degrees	
IFOV	0.054 degrees	0.075 degrees	0.111 degrees	
Swath width	0.31 x altitude	0.43 x altitude	0.64 x altitude	
Ground resolution @ 1000 m altitude	0.97 m	1.34 m	2.0 m	
ELECTRICAL CHARACTERISTICS				
Detector	MCT detector with maintenance-free cooler			
Number of spectral bands	254			
Spatial pixels	320			
Output	14 bits digital			
SNR	800:1 (peak) More detailed SNR data in various conditions available from SPECIM.			
Integration time	Adjustable, independent of frame rate			
Image rate	Up to 100 images/s			
Shutter	Electromechanical shutter for dark background registration, user controllable by software.			
Operating modes	Hyperspectral and multispectral The operator can create application specific band configurations, and quickly change from one mode or configuration to others in flight operation.			
Power consumption				
Complete system with rack PC	640 W			
Complete system with lightweight PC	515 W			
ENVIRONMENTAL CHARACTERISTICS				
Storage	- 20 ... +50 °C			
Operating	+ 5 ... +40 °C, non-condensing			

Disclaimer: specifications are subject to change without prior notice. Any errors or omissions are unintentional.

Swath width vs altitude

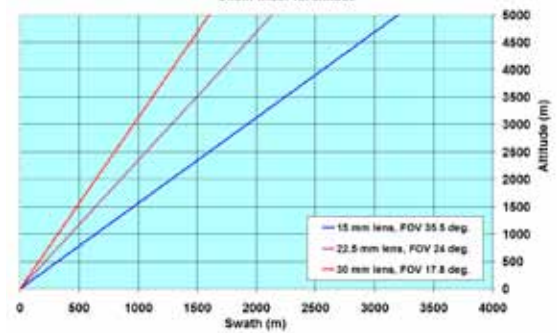

Ground pixel size vs. altitude

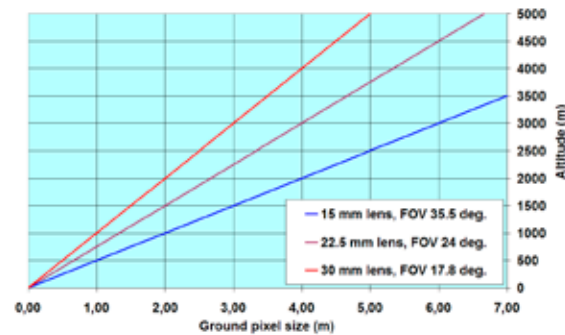
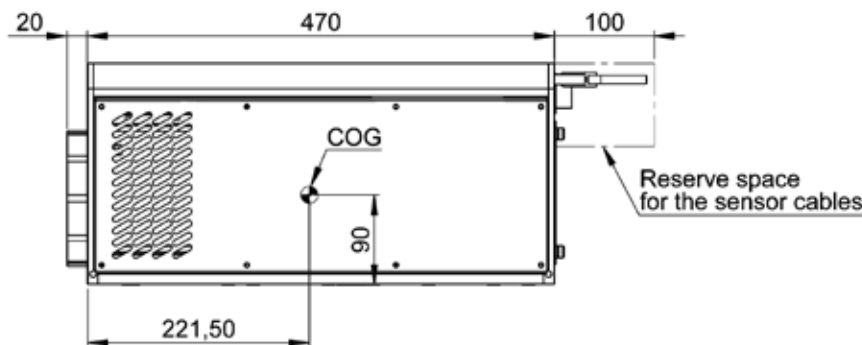
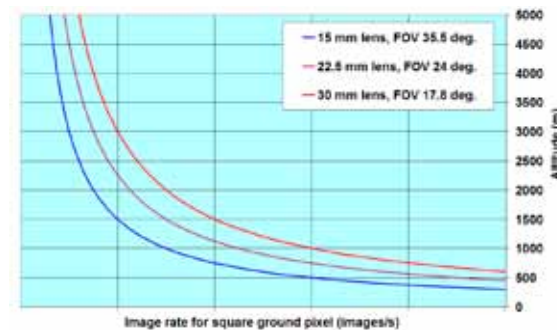
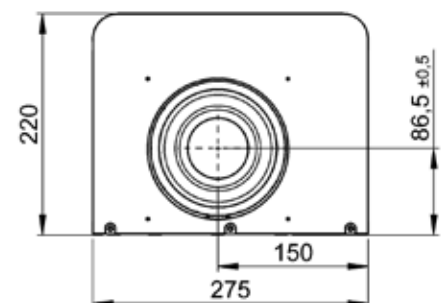

Image rate at aircraft velocity of 60 m/s (120 knots)



AisaHAWK sensor, side view



AisaHAWK sensor, front view