

# IMPECTOR <sup>UV</sup>

SPECIM's ImSpector series offers a unique imaging spectrograph for UV range. The spectrograph can be integrated with a UV sensitive CCD or CMOS camera, which when combined, creates a line-scan spectral imaging device. ImSpector UV4E provides high image quality and optical throughput from 200 - 400nm.

## Ultraviolet wavelength range

IMPECTOR		UV4E
<b>Optical characteristics</b>		
Spectral range		200 - 400nm
Dispersion		56.5nm/mm
Spectral resolution *1		2nm (30µm slit)
Bending of spectral lines		Smile ± 0.1nm
Image size		3.54 (spectral) x 8.8 (spatial) mm
Magnification		1 : 1
Spatial resolution *1		rms spot radius < 30µm
Bending of spatial lines		Keystone ± 3µm
Optical input		Telecentric
Numerical aperture		F/2.8
Average efficiency		> 50%, independent of polarization
Slit width, default		80µm (50µm slit available)
Slit length		9.3mm
<b>Mechanical characteristics</b>		
Body		Anonized aluminium
Size		(W)50 x (H) x 55 x (L) 165mm
Weight		320g
Lens and camera mount		Standard C-mount adapter
User adjustments		Rotating image axis relative to detector rows Adjustable back focal length ±1mm
<b>Environmental characteristics</b>		
Storage		-20 ... +80 °C
Operating		Non-condensing +5 ... +40 °C

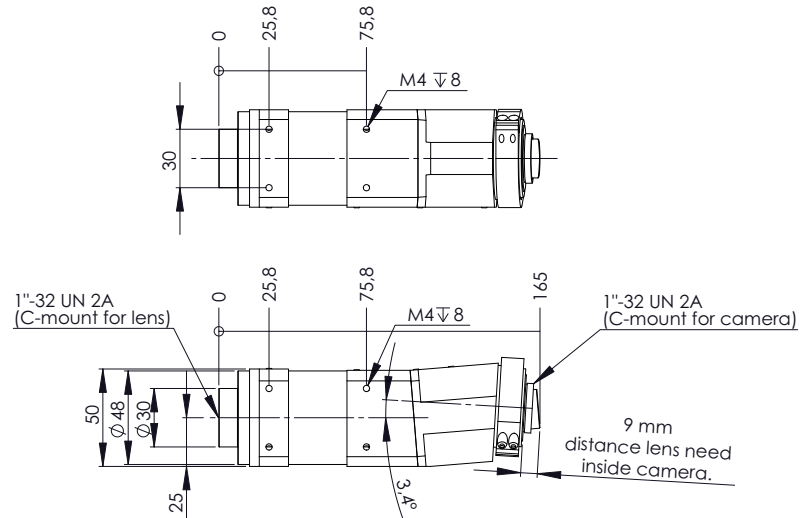

ImSpector UV4E mechanical dimensions

## Options, accessories

- Order blocking filter OBF260 (rectangular, 14 x 12mm)

\*1 System spectral and spatial resolutions also depend on the discrete imaging nature of detector and objective lens quality.



ImSpector UV4E spectrograph, side view



ImSpector UV4E spectrograph, front view